



Falköping

DISCSPREADER COMBI



- Spreader for salt liquid and salt, separately or mixed.
- Membrane pump and double feeders provide very exact dosage.
- Spreads: sand, shingle, salt and calcium chloride

Model

CLC-366

CLC-427

CLC-546

CLC-647

CLC-857



MODEL		CLC-366	CLC-427	CLC-546	CLC-647	CLC-857	S-MODEL
Volume, m ³	solution	3.6	4.2	5.4	6.4	8.5	1
	salt	6.0	7.0	6.0	7.0	7.0	
Weight, kg		1 700	1 900	1 900	2 100	2 300	
Feedscrew, Qty		2	2	2	2	2	
Spreading width, m		2-8	2-8	2-8	2-8	2-8	
Spreading quantity, g/m ²	solution	5-40	5-40	5-40	5-40	5-40	
	salt	5-30	5-30	5-30	5-30	5-30	
Spreading speed, km/hr	max	60	60	60	60	60	
Hydraulic flow at 1 000 rpm	min	40	40	40	40	40	
	solution/salt, l/m	max	60	60	60	60	
Hydraulic pressure min. bar		150	150	150	150	150	
Operating volatage, volts		12, 24	12, 24	12, 24	12, 24	12, 24	

Surface finish: Zink metallized, primer and 2-component topcoat.
Accessories: Hydraulic loading system, remote controlled spreading configuration, side jumpers, disc hoist, mixer, sidetanks, larger tanks, High-speed spreading etc

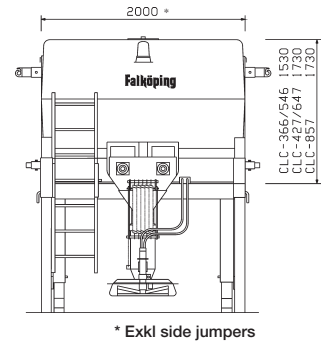

Extra equipment the spreader with high tanks (increases the height by 400 mm and the volume by 600 l per tank).

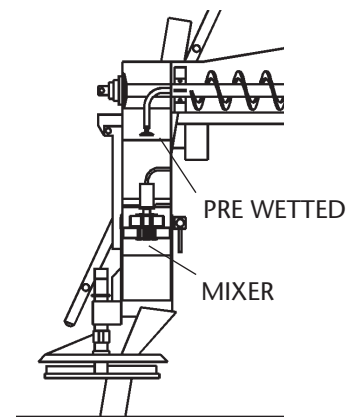
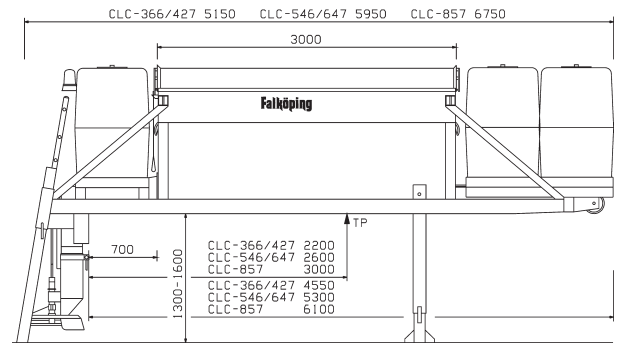

Mixer

- for making salt slurry. Effective disintegration of moistened salt for optimum slippery surface prevention with salt mixture.

High speed spreading

Our combi spreaders in the CLC series can be equipped with spreading nozzles which gives you the possibilities to spread in higher speed. The spreading nozzles completes the spreading disc and are automatically activated when the vehicle drives in higher speed.

- Higher speed when spreading
- Retained spreading pattern
- Spreading width up to 13 meters
- Automatic activation of the spreading nozzles when the vehicle drives in higher speed