



# Falköping

## LIQUID SPREADER TRACTOR

**Modell TC-05 TC-10  
TC-16 CLT**

- Operation from the tractor hydraulic system.
- Spreading width and quantity adjustment from the drivers cab.
- Instrument panel C-365 and Panel PC
- Spreads: sand, salt, shingle and calcium chloride

### TECHNICAL SPECIFICATION | DISCSPREADER TRACTOR

MODELL	TC-05	TC-10	TC-16	CLT-1.8/2.1
Volume sand/salt, m <sup>3</sup>	0.5	1.0	1.6	-
Volym liquid, m <sup>3</sup>	-	-	-	1.8/2.1
Empty weight, kg	310	370	430	600
Length, m	0.75	0.95	0.95	1.45
Width, m	1.50	1.50	2.00	2.50
Height, m	1.35	1.50	1.60	1.32/1.52
Oil flow, l/min	30-60	30-60	30-60	30-60
Oil pressure, bar	>150	>150	>150	>150
Total weight				
- sand, kg	1.100	2.000	3.000	-
- salt, kg	900	1.500	2.300	-
- liquid, kg	-	-	-	2700/3100
Spreading breadth, m	2-8	2-8	2-8	2-4
Spreading quantity, g/m <sup>2</sup>	5-200	5-200	5-200	10-20/40

**Accessories:** Dry material/pre-wetted dry material, mixer, combi type.

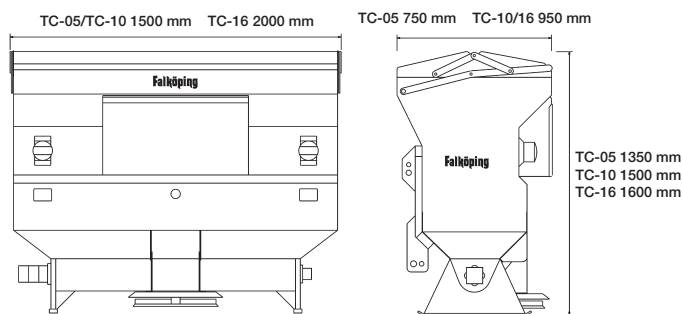

TC-05/TC-10/TC-16

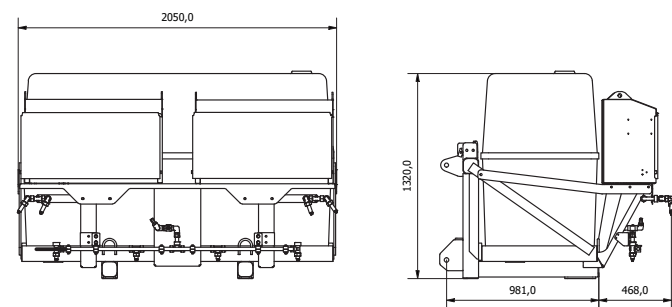

Liquid spreader CLT-1.8/2.1



De-icing of artificial turf.



Liquid spreader CLT-1.8/2.1